

EFFICIENCY OF USE OF TECHNOLOGIES AND TECHNIQUES OF REMOVAL DEVELOPMENT IN IMPROVING LAND RECLAMATION

Rajabov Yarash Jabborovich¹
Najimov Dilshod Kuvonch oglu²
Safarov Shavkat Tukhta oglu³

Abstract

The article provides a study of issues for improving the soil reclamation state in developed countries such as the USA, Canada, Japan, Holland, Belarus and many other countries without wrapping the soil with the use of technology and technology. For this purpose, in the conditions of the Bukhara region, a new improved drainage mole tool was developed with wide-coverage use in the autumn season before washing saline soils.

Keywords: Technology, Technical, Introduced, Complex, Chisel, Plows, Agriculture, Cultivator, Tillage, Reclamation.



¹ PhD doctoral, Bukhara Branch Institute of the Tashkent Institute of Irrigation and, Agricultural Mechanization Engineers, Uzbekistan
E-mail: yarabov62@mail.ru

² Students of Bukhara Branch Institute of the Tashkent Institute of Irrigation and, Agricultural Mechanization Engineers, Uzbekistan
E-mail id: dilshodbeknajomov@gmail.com

INTRODUCTION

Experts note that the use of non-tillage technology and technical means to improve the reclamation of lands in recent years has been highly effective. In this regard, the issue of finding solutions to the problems in Uzbekistan is urgent.

In the United States, Canada, Japan, the Netherlands, Russia, Belarus and many other countries, energy-saving, high-efficiency and high-quality processing technologies are being introduced in agricultural production.

In recent years, farming in Uzbekistan, as well as one of the new methods of land management in the "cluster" method, the organization of work on the basis of high efficiency has been considered important. The use of such technology and the achievement of minimal processing, cost reduction, quality, high-yield production, processing and other complex issues are relevant today.

So here are a few ways to work with minimal processing, without overturning:

When soils are treated with a non-rolling hull, the soil hardly mixes, the layer stays in place without overturning, the density decreases and the porosity increases. But a plow without a roller will not ensure good soil compaction. Chisel plugs are widely used in foreign countries. These devices ensure good soil compaction with low energy consumption.

Currently, chisel plows (softeners) produced by foreign companies are used in agriculture, equipped with soft teeth mounted on hard and spring-shaped columns. The PCH-4.5 chisel plug-deep softener, equipped with a Russian-made chisel and axial teeth, is designed for deep tillage and tillage without tilting the soil [1].

At present, many types of combined machines with different working bodies are produced in foreign countries:

Kvemeland (Norway) manufactures hanging CLC cultivators and trailer Stemtiler cultivators for tillage [2]. The CLC cultivator is designed to loosen the soil to a depth of 40 cm without overturning and to cultivate the furrowed fields. This cultivator is aggregated with Class 3 tractors. Coverage width of the unit is 3 m, working speed up to 8 km / h, number of working bodies 15, working capacity 2 ha / h. Examples of combined vehicles are RVK-3.0, RVK-3.6, RVK-5.4 and RVK-7.2. They loosen, flatten, crush, and compact the soil in a single pass through the field. However, such combined aggregates have several disadvantages: in the treatment of soils with high humidity, the soil sticks to the ring rollers and gets stuck in the softening bodies; high energy intensity of the technological process has a negative impact on the efficiency of the unit; low technological and operational reliability in weed fields.

The stern cultivator is designed for 4 working areas before tillage: in the first zone the soil is leveled using a leveling beam; in the second zone, the soil is loosened by three rows of incisors or two rows of incisors; in the third zone, the surface layer of the soil is treated with a needle roller; in the fourth zone, the roller breaks the ground. The unit has an operating capacity of up to 7 ha / h, a coverage width of 6 m, and is aggregated with Class 4 tractors [3,4,5].

Amazon's Centair combined unit is designed to prepare the soil for planting in a single pass, and several modifications of this cultivator, the Centair 3002, Centair 4002, Centair 5001, Centair 6001, and Centair 7501, are produced. [6] The Cenius Amazone cultivator, designed for medium and deep tillage, cuts holes during work with softeners and delivers them to the rollers using mixing discs. This technique is used to cultivate the harvested fields without spilling them on the

ground.

The location of the working bodies of the unit allows you to quickly mix the remains of the pit with the soil after harvesting, which ensures uninterrupted operation, even when the pit is large.

Foreign companies equip their cultivators with different types of working bodies, which ensures their efficiency in different conditions. When designing a Chiselli weapon, the working bodies should be positioned in such a way that not only eliminates soil congestion between the working bodies, but also ensures low energy consumption and high productivity.

CHK-3.0, CHKU-4A chisel-cultivators, GRP-3/5, GNU-1MS deep softeners, especially chisel-cultivators, produced in Uzbekistan for surface and deep tillage, are plowed, irrigated or irrigated. The washed fields are designed for processing at a depth of 14-20 cm in early spring. Dredgers are designed to loosen the underlying layer by about 50 cm and are not widely used in agriculture due to their significantly higher tensile strength [7].

The KPG-250A, PG-3-100, PSH-3 and PSH-5 cultivators, equipped with flat-cutting machines, are also designed to maximize the maintenance of maize stalks and grain residues left on the harvested field surface. Therefore, they are used in desert areas with wind erosion and insufficient humidity.

Equipped with a wide range of hydraulically operated flat cutters, the KPSH-9, KPSH-5 and KPSH-11 cultivators are designed for basic tillage of the rest of the plow and tillage to a depth of 1820 cm before planting. In doing so, it leaves plant debris on the surface to protect the soil from wind erosion.

The KPSH-9 consists of a cultivator frame equipped with flat cutting bodies, nine working bodies, two support wheels and automatic coupling mechanisms. Its working parts are arranged in two rows. Each row is equipped with anti-roll bar. This device is aggregated with Class 3-4 tractors [9].

In improving the reclamation of soils in Uzbekistan, ie gypsum and birch soils recommended for use before autumn saline washing on the basis of special technology, chisel softeners and devices for creating drainage holes in soils with high salinity developed and recommended to improve the reclamation of lands in agriculture.

Chisel-type softener: Chisel-type softener has a minimum gravitational force at the radius of curvature of the column at a radius of curvature of 0.20-0.25 m when the forward protrusion of the working body $L = 0.210$ m, working depth $N = 0.45$ m is explained by a decrease in the frictional force between and the soil.

An increase in velocity from 1.10 m / s to 2.55 m / s, in turn, led to an increase in gravitational force. The optimal parameters of the resource-efficient chisel softener were determined using multifactor experiments, and the working body was $N = 0.45$ m and $L = 0.210$ m at $V = 2.1$ m / s, $R = 0.230$ m, $\rho = 0.15$ m. formed [10].

The chisel softener is used to soften gypsum and birch soils before autumn saline washing using a special closed technology. Designed to increase the softening of gypsum and birch layers of soil without the addition of topsoil.

The main parameters, parameters and values of the hole-forming device are: the diameter of the hole drainage is $d_m = 50-150$ mm in medium soils and $d_m = 100-300$ mm in stable soils;

$\ell_u = (1,5 - 2,0)d_m$ the length of the conical end cylinder; unit speed $\mathcal{G}_{io} = 0,6 - 1,0$ km / h; the length of a steel rope is given by $\ell_a \geq (0,1 - 0,15)$, m. The change in the tensile strength of the working bodies depending on the length of the steel rope was due to its tensile strength of at least 5.1 kN when the conical end cylinder with a diameter of 0.10 m was pulled with a steel rope with a length of 0.30 m. Theoretical and experimental studies have shown that the quality of porous drainage formed in this process, the absorption of groundwater is 0.45 m / day, is considered an acceptable option [11].

The hole drainage device is mainly used to create a hole drainage under the plowed layer of saline soils and to improve the reclamation of the lands.

These devices are included in the tillage equipment and are used to improve the reclamation of lands in agricultural conditions.

Advanced perforated drainage forming device. The new method, which is recommended to improve the reclamation of lands, differs from the existing ones in that it is recommended to be used every two years, with high productivity, high quality of work and economic efficiency.

The 1-middle frame suspension of the perforated drainage device is fitted with 2-P-shaped end frames, then the longitudinal frame of the edge frames is transported in a transport position by means of 3 markers and 4 marker springs. Depending on the mechanical composition of the soil and the degree of salinity, it is also possible to provide layered tillage of the working columns. Formation of perforated drains by changing the 6th middle work column to 40 cm and the 5th edge slope to both side work columns to 80 cm or vice versa, both side work columns to 40 cm and the middle work column to 80 cm possible. It is possible to organize the application of this tillage technology in heavy mechanical soils before autumn saline washing by selecting the optimal option with intermediate tillage distances of 80 cm on both sides and 40 cm on the middle working column. (Figure 1).

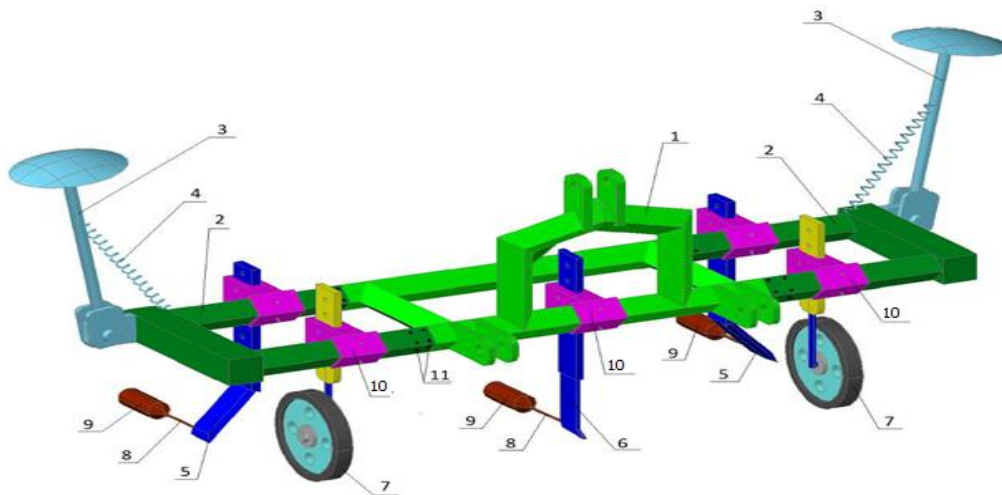

1-middle frame suspension; 2-P-shaped edge frames; 3- markers; 4-marker spring; 5-edge sloping work columns; 6- straight right work column; 7- support wheels; 8- steel ropes; 9- conical end cylinders; 10- support wheels and workbenches for lifting and lowering, and 11-P-shaped edge frames with bolts securing to the middle frame. Figures 6, 8, and 10 are the cross-sections of the work tips.

Figure 1. Profile view of an advanced perforated drainage device

The dimensions of the work columns are a bit more complicated than the constructive scheme of the 5th edge work columns on both sides and its construction, i.e. the top 50 cm is straight and the remaining 50 cm is 120-1300 vertical to the left and right. Thus, it is advisable to prepare the lobovoy part as a sharp panasimon. The structural scheme of the 6th medium straight work column is simple and not very complicated to make, that is, to prepare the front lobovoy part of a metal sheet of 120-130 cm in length with a height of 90-100 cm and to remove the front of the work columns. It is advisable to prepare in a ponasimon form in order to prevent the preservation of wire root remnants and soil accumulation. This serves to improve the working quality of the device and reduce the traction force. The 6th straight straight working column and the 5th right and left oblique working column and the 9th conical end cylinders are attached to it by 8 steel ropes behind it. The 10th support wheels and workbenches are fastened using bolts that lift and lower the 11-P-shaped edge frames to the middle frame [12].

The 6-straight work column cuts the soil in a vertical direction, then the 9th creates conical drains using conical end rollers, and the 5th right and left side-sloping work columns cut the soil from the side. cut, then form a perforated drain. In this case, the water supplied under pressure from above during the autumn saline washing causes the column to collapse quickly due to the fact that it falls into the hole drainage through the vertical section of soil cut in the right direction. 5 The long-term, quality work without breaking is due to the fact that the pressure of water on the soil section is less than the vertical soil section formed on the right work column, because the soil section formed under the influence of two-sided work columns is from the side. which in turn can maintain its activity. The resulting perforated drains serve for efficient operation. Choosing the right middle work column 6 serves to ensure the correct distance between the work columns on both sides, while its rapid collapse is a downside. It is also important to choose which work column to create a hole drain on the first floor when working with a floor drainage device. This allows you to make the right choice depending on the mechanical composition of the soil and the level of salinity to be treated before the autumn saline wash.

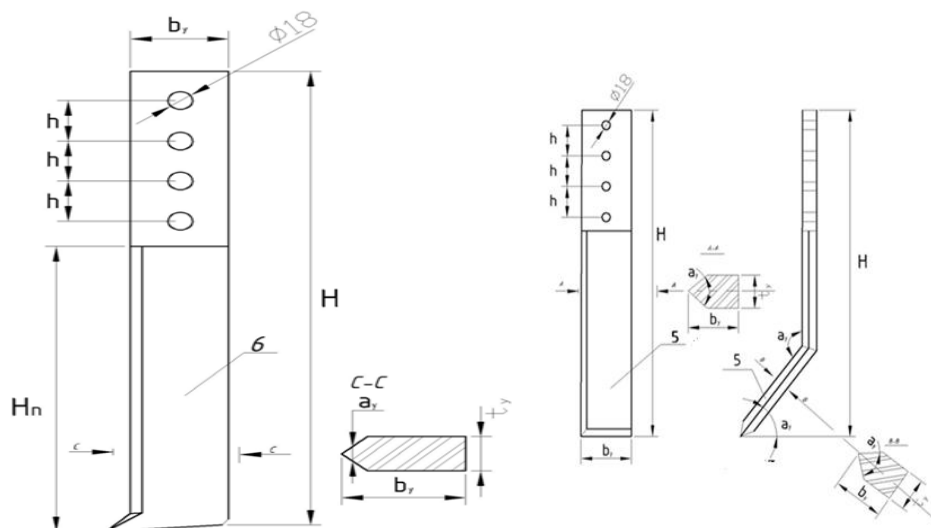

Figure 2. Advanced perforated drainage forming device middle and side work columns

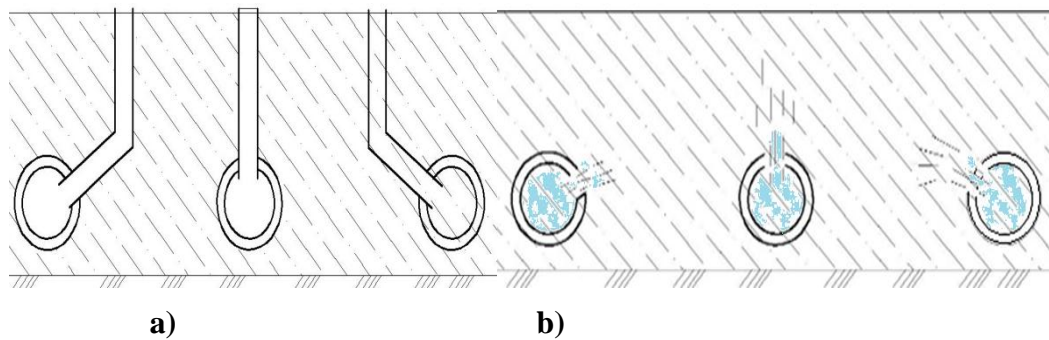

Figure 3. Advanced perforated drainage forming device middle and side work columns

The design of this proposed new hole drainage device differs sharply from the design of the existing hole drainage device, and its efficiency in removing harmful salts from the soil during saline washing is 6-7 times higher, which improves the performance of hole drainage in salt washing. does.

The device can be used to increase reliability, work efficiency, increase the quality and efficiency of borehole drainage, reduce energy consumption and improve land reclamation. The device consists of three working bodies, the first working body is mounted on the front frame and the side working bodies are tilted to the left and right at an angle of 58-60° to the ground. The working depth of the front working column forms a perforated drain at a depth of 80 cm. The two side working columns enter at a depth of 40 cm at an angle of 58-60° from the side, forming a perforated drainage. This, in turn, prevents water from entering from the top under vertical pressure. This, in turn, prevents the perforated drain from collapsing quickly. Due to the fact that the perforated drainage formed from the middle working column is formed at a depth of 80 cm, the upper pressure of the water is slightly reduced, but still due to the penetration of the drainage hole along the vertical section from above, it is quickly crushed and filled with soil. The efficiency of the work due to the removal is the same as that of the perforated drain formed at a depth of 40 cm. The distance between the perforated drainage tracks formed on both sides is 4 m to 8 m relative to the working column in the middle. The efficiency of the perforated drain, formed by the middle working body, is the same as that of the 40 cm treatment, which is explained by the fact that the gravitational force is twice as high. The distance between the working bodies is 4 m. This requires the organization of processing of the hole-forming device every 2-3 years.

In agriculture, it is possible to improve the reclamation of lands, to create a hole drainage under the topsoil, to reduce harmful salts in the soil by 6-7 times after the autumn saline wash.

REFERENCES:

1. Yuzbashev V.A., Sokolov A.V., Kuznetsov Y.A. Osobennosti konstruksiy i tendensii razvitiya chizelnix orudiy. - M.: Selskoxozyaystvennie mashini, 1977. - 42 b [Design features and development trends of chisel guns.] - M.: Agricultural machinery, 1977.
2. Gribovskiy A.P. Kompleks protivno-eroziionnix mashin.- M.: Agropromizdat, 1989. - 151 b. [Complex of anti-erosion machines.] - M.: Agropromizdat, 1989. - 151 p
3. Selskoxozyaystvennaya texnika dlya intensivnix texnologiy. - M.: AgroNIIT EIITO, 1988. - 287 b. [Agricultural machinery for intensive technology.] - M.: AgroNIIT EIITO, 1988. - 287 p.

4. Vilde A.A. Kombinirovannyye pochvo-obrabativayushie mashini. -L.: Agropromizdat, 1986. - 128 b. [Combined tillage machines. -L.: Agropromizdat], 1986.- 128 p.
5. Jo‘raev F.O‘. Energiyaresurstejamkor chizelli-yumshatgichni qo‘llash texnika va texnologiyasi. **Monografiya**. O‘zbekiston Respublikasi Fanlar Akademiyasi. “FAN” nashriyoti. -Tashkent, 2012. 3-165 b.
6. O‘zR patent № UZ FAP 00832. Drenaj-tyuynuk ochuvchi mashina Osma Moslamasi. / Jurayev F.ŷ. // Rasmus axborotnoma. 2013 yil. -№7.[Patent RUz # UZ FAP 00832.
7. Talabnoma № FAP 20190008 "Tuyukuli drenaji uchun qilinadigan qurilma".